

FRONT VIEW

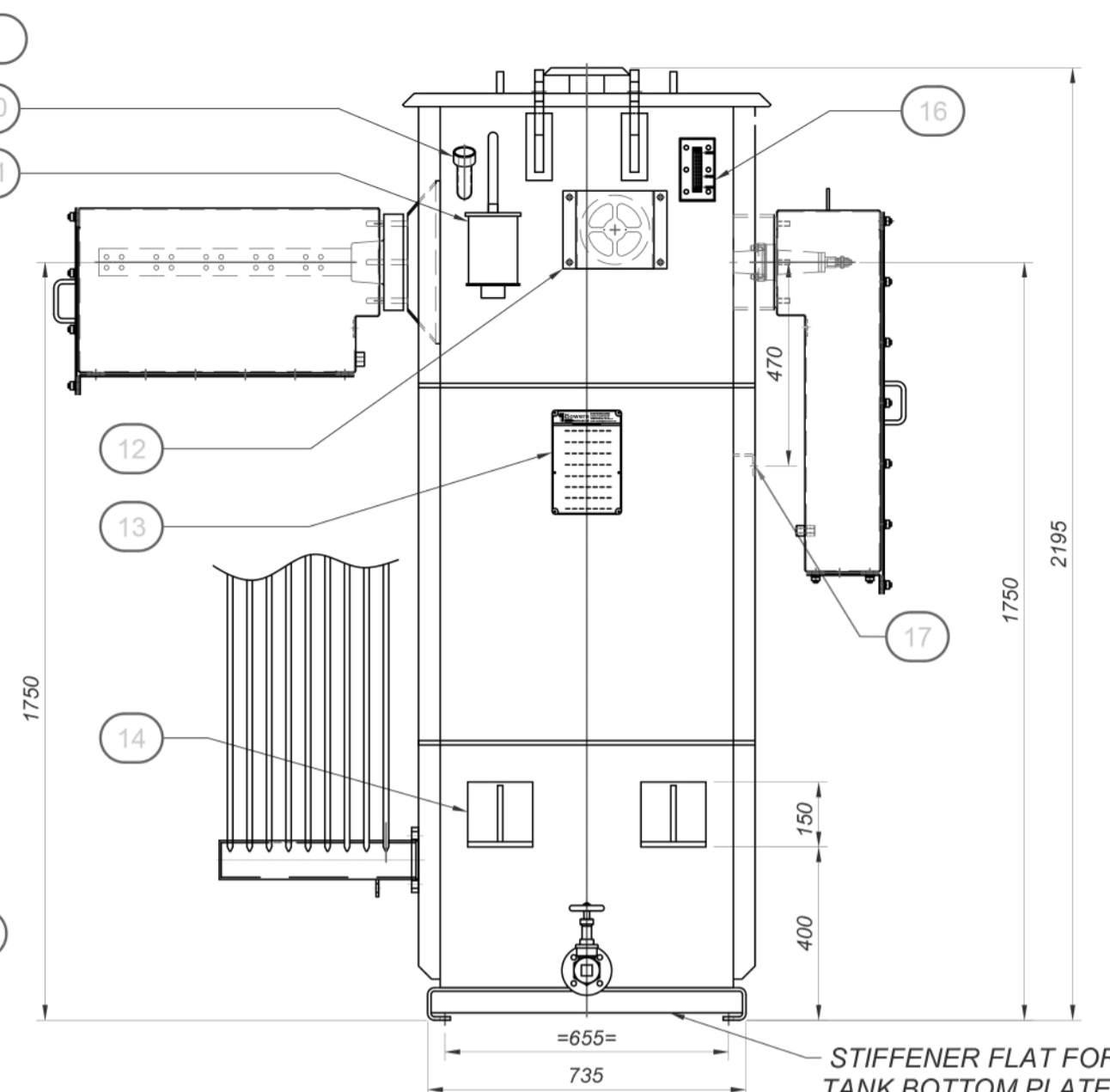

SIDE VIEW

WITHOUT RADIATOR FOR CLARITY

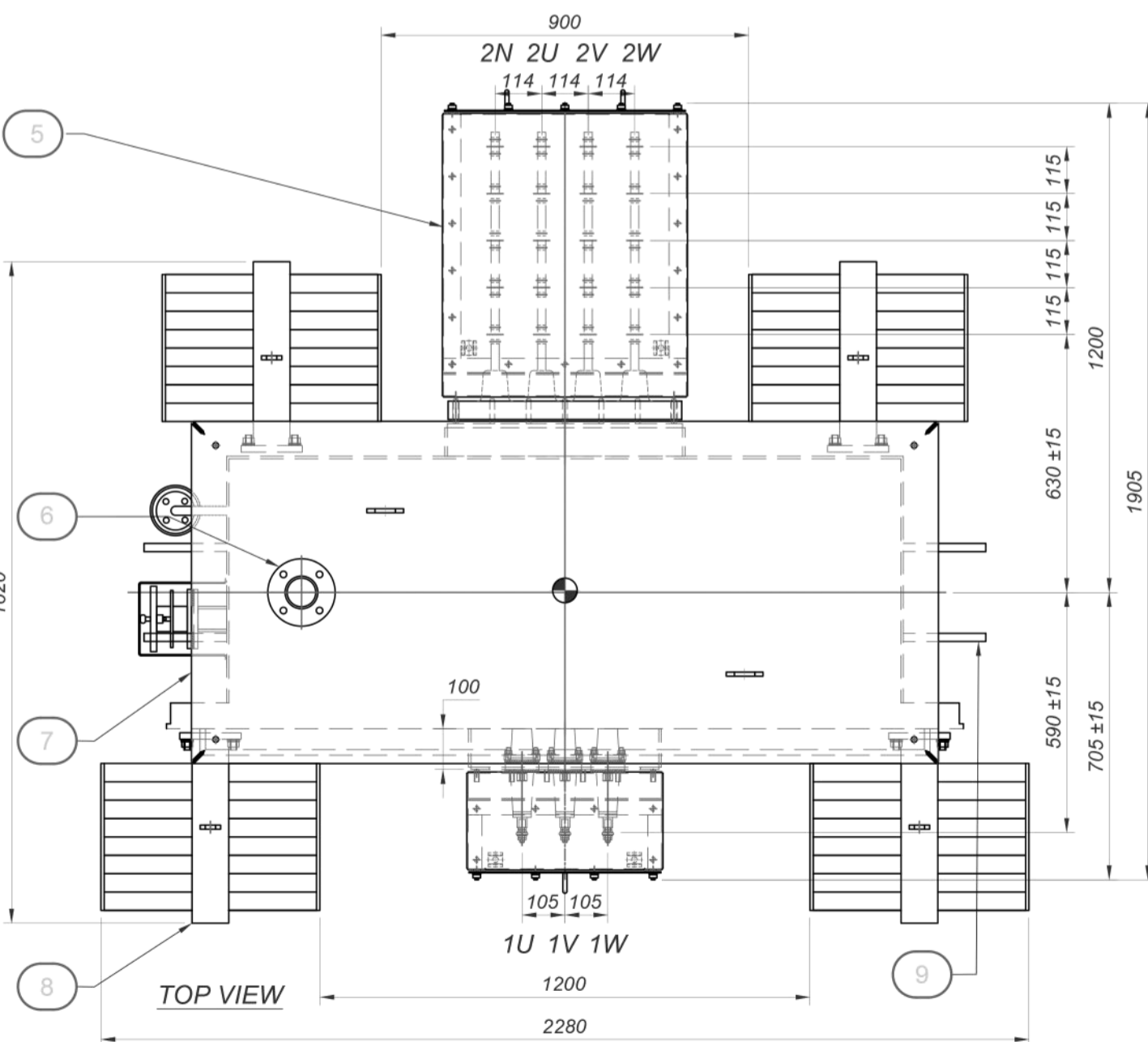

TOP VIEW

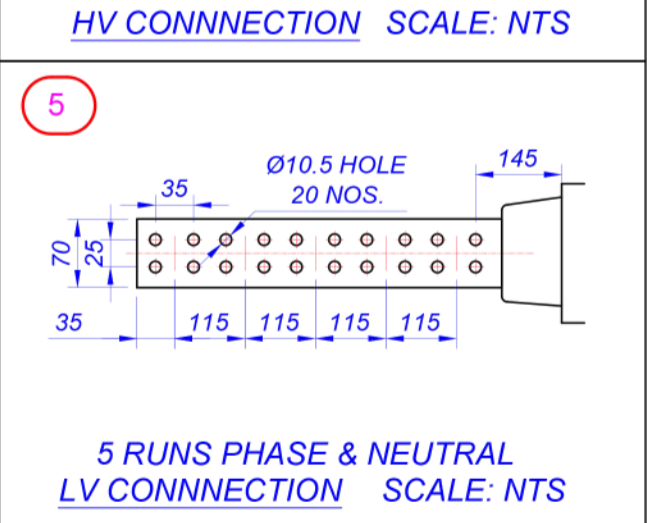
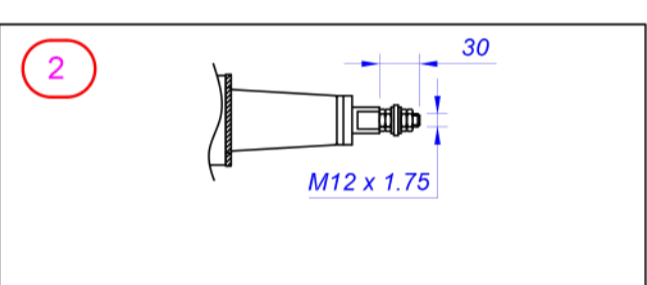
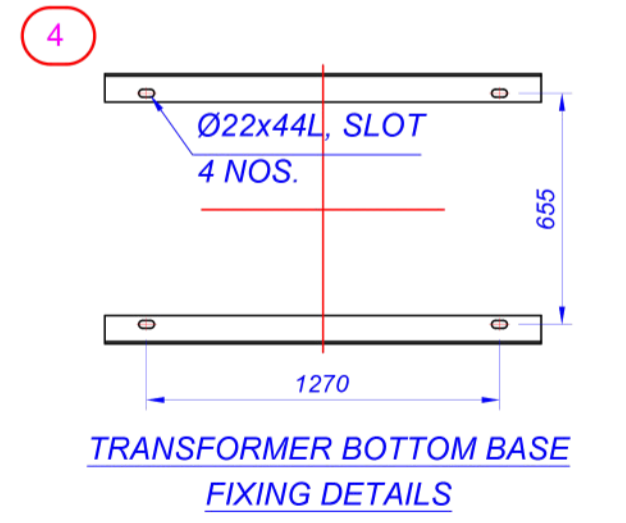
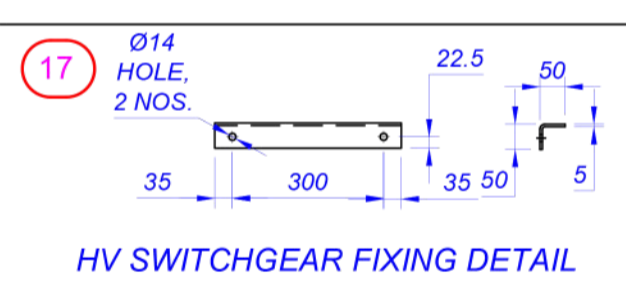

- NOTES:-
- DIMENSIONS & WEIGHTS ARE SUBJECT TO ±5% TOLERANCE.
  - PAINTING: DARK ADMIRALTY GREY 632 OF BS 381C, ISO-12944-2 CATEGORY C4
  - THIS IS OGA DRAWING ONLY, EXACT LOCATION OF ACCESSORIES & FITTING MAY VARY DURING MANUFACTURING.
  - EXCEPT OUTLINE ARRANGEMENT OF TRANSFORMER ALL PART DETAILS PREPARED FOR NOT TO SCALE FOR BETTER VISIBILITY
  - HV, LV CABLE BOX GLAND PLATES WILL BE PROVIDED WITH Ø6 MM PILOT HOLES

17	HV SWITCHGEAR FIXING DETAIL (50x50x5 THK. MS.ANGLE)
16	PRISMATIC OIL LEVEL INDICATOR
15	EARTHING TERMINAL SUITABLE FOR M12 BOLT (ONE ON EACH SIDE) (SS-316)
14	JACKING PADS
13	RATING AND TERMINAL MARKING PLATE
12	OFF-CIRCUIT TAP SWITCH (MODEL: 12kV 100A, 6 POSITION) WITH ENCLOSED COVER
11	BREATHER FIXING PIPE WITH 3/4" BSP MALE CONNECTION (BREATHER WILL BE SUPPLY LOOSE)
10	THERMOMETER POCKET SUITABLE FOR 3/4" BSP MALE CONNECTION
9	LIFTING LUGS FOR COMPLETE TRANSFORMER
8	PSR RADIATOR BOLTED TYPE (1200X520X9 FINS)
7	BOLTED TYPE TOP COVER
6	LIQUID FILLING PIPE WITH COVER
5	LV CABLE BOX 4 POLE, 5 CONNECTION/PHASE WITH 1.1KV EPOXY MONOBLOCK BUSHING AS PER BS2562
4	SKID TYPE UNDER BASE ARRANGEMENT (Ø35)
3	DRAIN VALVE WITH PLUG & SAMPLER (MODEL : 40 mm, PN16)
2	HV CABLE BOX ASSEMBLY (3 POLE) WITH BS 2562 12kV, 250A PORCELAIN BUSHINGS (TERMINATION KIT REQUIRED)
1	LIFTING LUGS (ONLY FOR TOP COVER)
SL.No.	DESCRIPTION

BOWERS JOB No.	-
OUTPUT	2500 kVA
VOLTAGE RATIO	11000 / 415
AMPERES	131.22 / 3478.0
PHASES	3
FREQUENCY	50Hz
VECTOR SYMBOL	Dyn11

ESTIMATED WEIGHTS	KG
CORE AND WINDINGS	3650
COOLING LIQUID	1295 LTRS
TOTAL WEIGHT	6300



This drawing is **COPYRIGHT** and the property of Bowers Electricals Ltd. It must not be copied (in whole or in part) without prior written consent of the company. ©

TOLERANCE UNLESS OTHERWISE STATED  
 ± 0.5mm FOR DIMENSIONS UP TO 250mm;  
 ± 1mm FOR DIMENSIONS UP TO 1000mm;  
 ± 2mm FOR DIMENSIONS OVER 1000mm.

RevNo	Revision Note	Date	Signed	Checked

**Bowers**  
Electricals Ltd  
Heanor Gate Road, Heanor,  
Derbyshire, DE75 7GX  
Tel: 01773 531531 Fax: 01773 716 171  
Email: enquiries@bowerselec.co.uk

Drawn by SAMPLE	Checked by SAMPLE	Approved by SAMPLE	Job No. STOCK	Date 16/04/21	Size A2
GENERAL ARRANGEMENT OF 2500KVA 11000/415V TIER 2 TRANSFORMER			DRG No. FOR INFO ONLY		
FIRST ANGLE			Scale 1:15	Revision 1/1	Sheet 1/4