

**GENERAL ARRANGEMENT OF
800KVA 11000/415V BOWERS
ENERGY SAVING TRANSFORMER
(B.E.S.T.)**

Drawn By: T.B. Checked By: J.R. Approved By: J.C.

Job Number: -

Date: 11/05/22

FIRST ANGLE

Scale: 1:15 Size: A2 Sheet: 1/1

Rev No: Revision Note: Date: Drn: App:

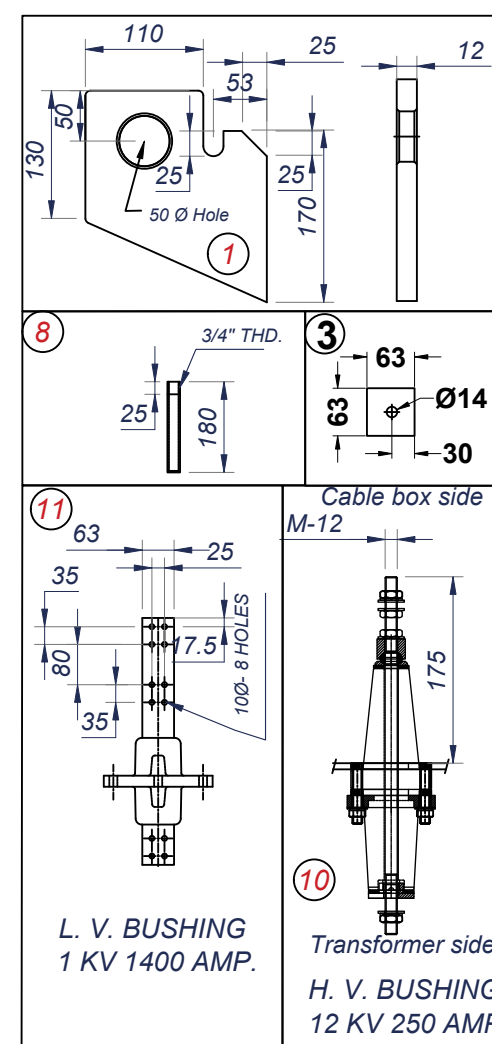
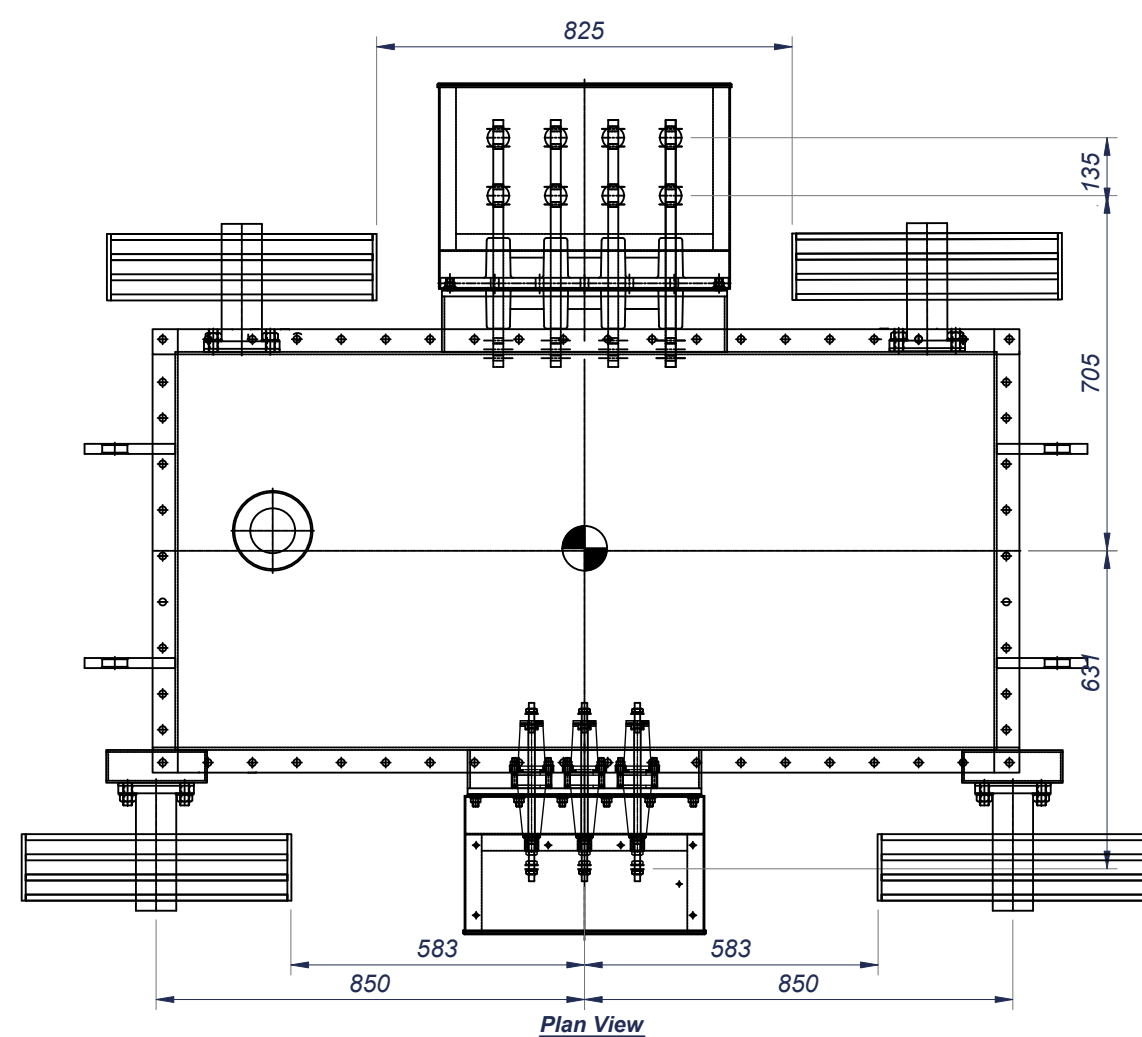
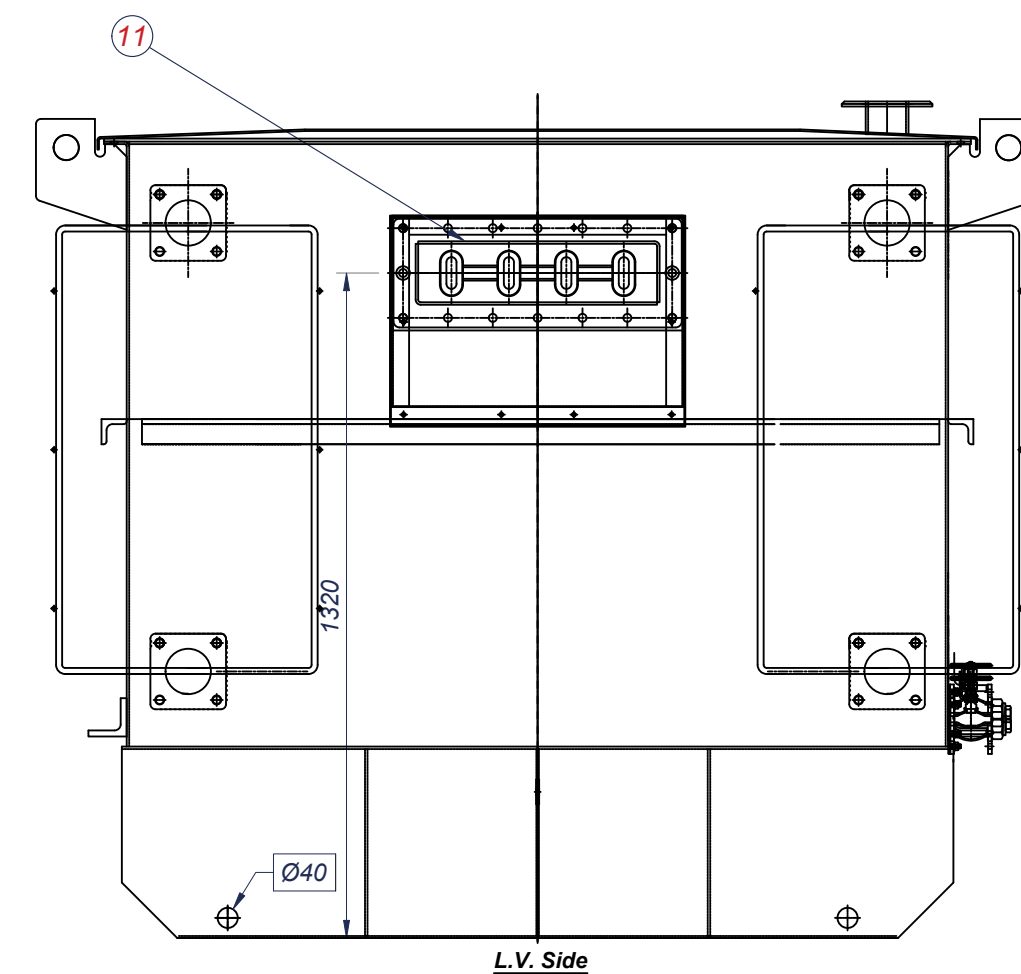
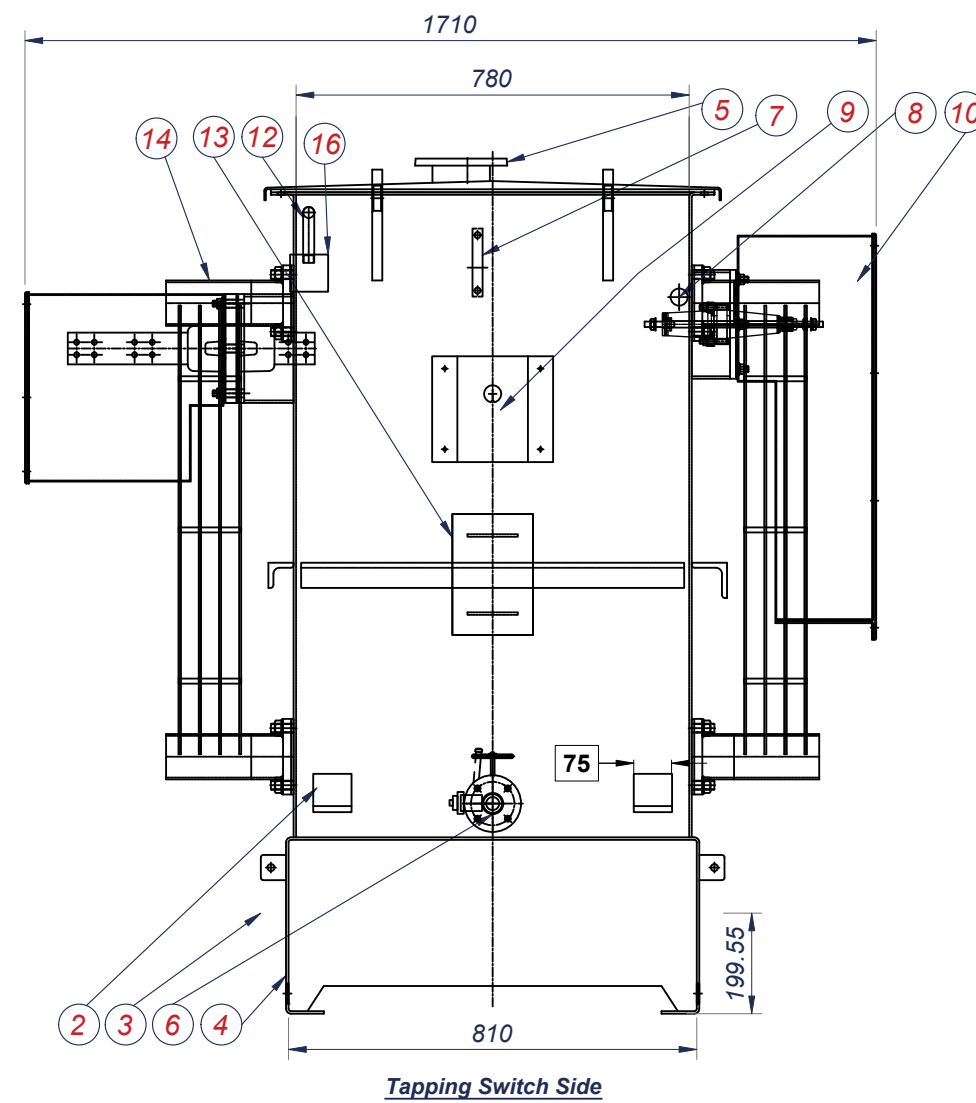
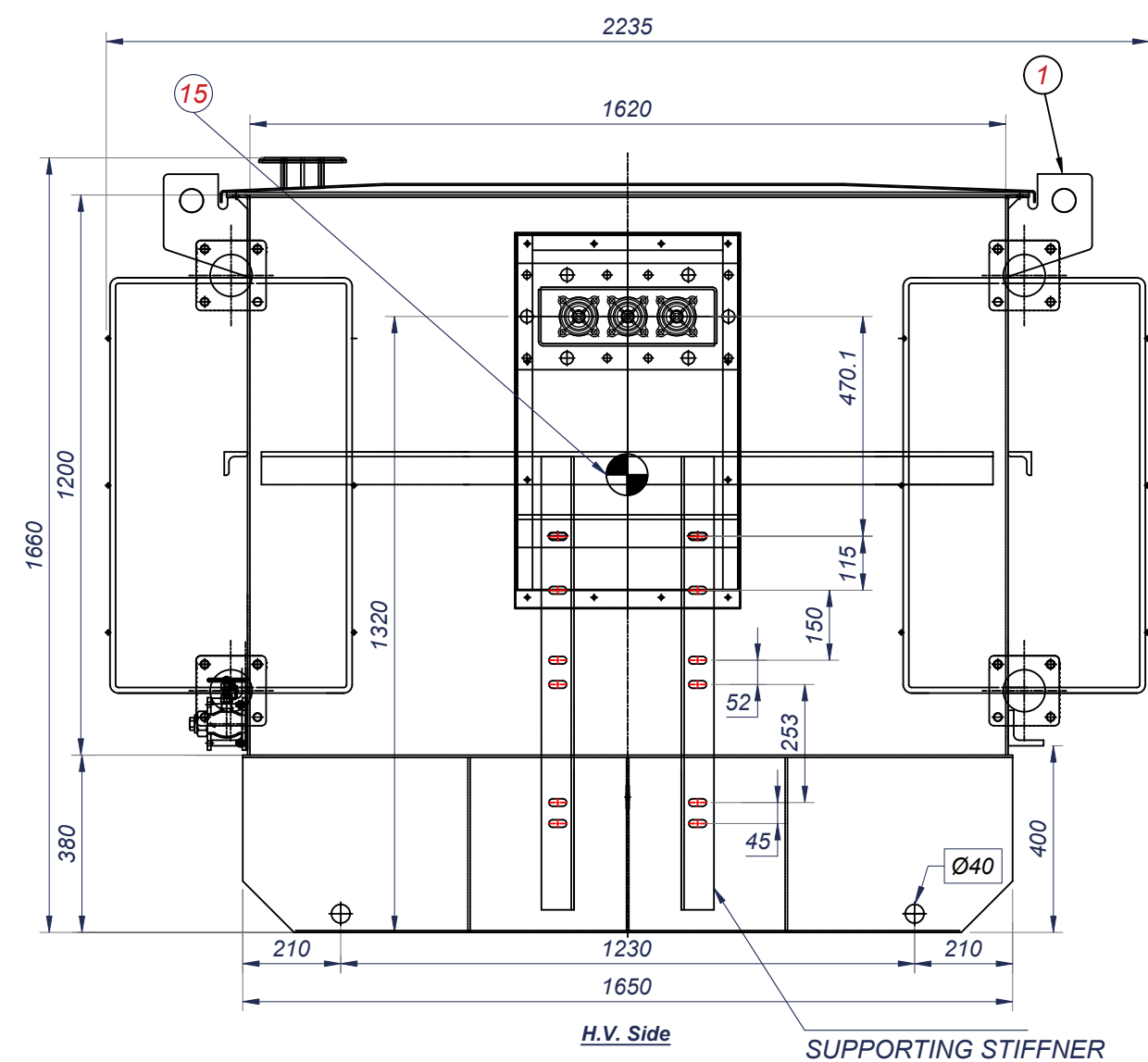

16	SILICA GEL BREATHER (non-Cobalt Chlorine) LOOSE SUPPLIED
15	LABEL OF CENTER OF GRAVITY
14	HEADER TYPE RADIATOR 900 CENTER , 4 PANELS
13	RATING AND DIAGRAM PLATE
12	AIR VENT PIPE
11	L.V. TERMINATIONS
10	H.V. TERMINATIONS
9	EXTERNALLY OPERATED OFF-CIRCUIT TAPPING SWITCH (ENCLOSED IN A PROTECTIVE MS COVER)
8	THERMOMETER POCKET
7	LIQUID LEVEL INDICATOR
6	1\"/>

NOTES:
1- DIMENSIONS, WEIGHT & VOLUME ARE SUB TO ± 10% TOL.
2- THIS DRAWING SHOWS ONLY GENERAL DISPOSITION OF FITTINGS.
3- FOR THE SAKE OF CLARITY CERTAIN FITTINGS SHOWN IN ONE OR MORE VIEWS HAVE BEEN OMITTED FROM OTHER VIEWS.
4- HOWEVER LIMITATIONS AS PER SPEC. WILL BE MAINTAINED.
5- H.V. TERMINATIONS (GLAND PLATE MATERIAL=MS)
6- L.V. TERMINATIONS (GLAND PLATE MATERIAL=AL)
7- POLE CABLE BOX COMPLETE WITH UNDRILLED GLAND PLATE. SUITABLE FOR FULLY INSULATED DRY TERMINATIONS AND CAPABLE OF ACCEPTING 1x3 CORE 185 mm Sq. OR 3x1 CORE 300 mm Sq. CABLES ENTERING FROM BELOW. INSULATING MATERIALS, CABLE GLANDS AND CABLE LUGS ARE NOT INCLUDED.
8- L.V. TERMINATIONS (GLAND PLATE MATERIAL=AL)
9- POLE AIR INSULATED CABLE BOX COMPLETE WITH UNDRILLED GLAND PLATE AND CAPABLE OF ACCEPTING 8x1 CORE CABLES UP TO 630 mm ENTERING FROM BELOW. CABLE TERMINATION KITS, GLANDS AND CABLE LUGS ARE NOT INCLUDED.
10- Paint Finish To ISO12944-2 Category C4 With a Dark Grey Semi Gloss Finish.

BOWERS JOB No.	-
OUTPUT	800 kVA
VOLTAGE RATIO	11000 / 415
AMPERES	41.99 / 1112.97
PHASES	3
FREQUENCY	50Hz
VECTOR SYMBOL	Dyn11

ESTIMATED WEIGHTS	KG
CORE AND WINDINGS	1945
COOLING LIQUID 930 LTRS	790
TOTAL WEIGHT	3705

Revision: 0

This drawing is COPYRIGHT and the property of Bowers Electricals Ltd. It must not be copied (in whole or in part) without prior written consent of the company. ©

TOLERANCE UNLESS OTHERWISE STATED
± 5mm FOR DIMENSIONS UP TO 250mm
± 10mm FOR DIMENSIONS UP TO 1000mm
± 20mm FOR DIMENSIONS OVER 1000mm

